

RECOMMENDED PANEL CUT

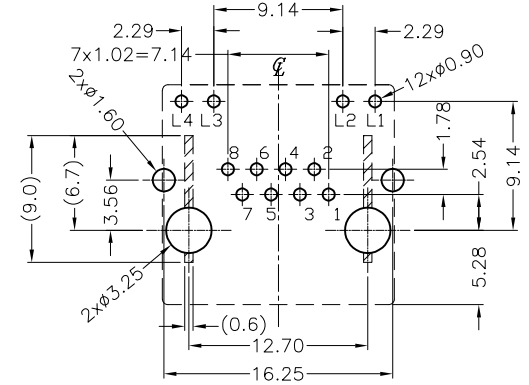
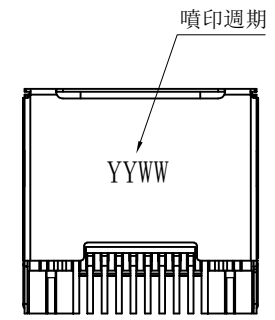
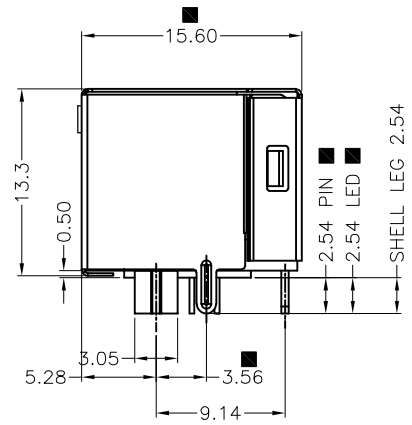
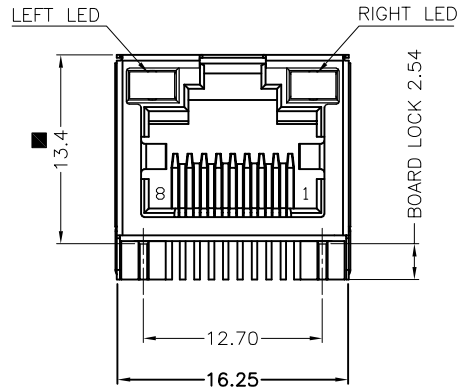

RECOMMENDED PCB LAYOUT COMPONENT SIDE TOLERANCE ±0.05

P/N RULE:

JT1A-D 2 1 1-Y G J M - 1

SHELL CODE: 2 1 1-Y G J M - 1
W/O SPRING
W/O BACK LEG
W/O LOGO
Housing: PBT Black

LED CODE: 1-Y G
LEFT LED: YELLOW
RIGHT LED: GREEN

PIN 2.54mm
小基脚型LED

0.1U" Min Gold
For All(圓PIN)

外壳柱子脚长2.54mm

- NOTES:
- MATERIAL:
HOUSING: HIGH TEMPERATURE THERMO PLASTIC (UL94V-0)
CONTACT: PHOSPHOR BORNZE $\phi 0.46\text{mm}$
SHELL: SUS201-1/2H T=0.20mm
 - FINISHED:
CONTACT: 50u" MIN. NICKEL UNDERPLATING ALL AREA, 100u" MIN. TIN ON SOLDER TAILS, SELECT GOLD PLATING ON CONTACT AREA.
SHELL: 30u" MIN. NICKEL PRE-PLATING ALL AREA
 - JACK CAVITY CONFORMS TO FCC RULES AND REGULATIONS PART 68.500 (D) (2)

| REV. | ECN. NO. | DRAWN | DATE | EC.content |
|------|----------|-------|------------|------------|
| A.0 | NEW | Tony | 04/30/2020 | - |
| | | | | |
| | | | | |



| APPROVED | CHECKED | DRAWN | UNIT: mm | SCALE: 1:1 | SHEET: 1/1 | REV.: A.0 |
|----------|---------|-------|----------|------------|------------|-----------|
| | | | | | | |

DOCUMENT NO. : ZER0013/A.3

說明: △: 備註 ◇: 版本變更 (N): 尺寸序號 ■: 重點尺寸 ▼: CPK尺寸

SIZE: A4